

Product Information.....2

Introduction.....3

Safety Instructions..... 4

Responsibilities of Owners & Users.....5

 Removal from Service..... 5

 Repairs..... 5

 Operators..... 5

 Before Operation..... 5

 During Operation..... 5

 Modifications and Alterations..... 5

Description of Equipment..... 6

Operation of Equipment..... 6

Installation..... 7

 Voltage Requirements..... 7

 Remote Motor Starter..... 7

 Internal Motor Starter..... 8

 Operation..... 8

 Electrical Schematic..... 9

 Leveling the Unit.....10

Using your Upender..... 12

 Operating Condition..... 12

 Chain Breakage..... 12

Safe Operating Procedure..... 13

Maintaining Your Upender..... 14

 Daily Operator Checks..... 14

 Quarterly Maintenance..... 14

 Lubrication..... 15

 Chain Tensioning & Replacement..... 15

 Adjustment Procedure..... 15

 Chain Replacement..... 16

 Limit Switches..... 16

 Replacement Parts List..... 17

Warranty.....18

Product Information

This Service and Replacement Parts Manual applies to the following Bushman AvonTec machinery:

Product Type:	Mechanical Upender
Model Number:	
Rated Load Capacity:	
Serial #:	
Registered User:	
Date Shipped:	

For warranty information, service, and replacement parts information; please call your local dealer or Bushman AvonTec at (800) 558-7850.

This manual should be kept with the machine at all times. In the event the machine is re-sold, or transferred to another facility, please contact the factory so that we can update our service and warranty records.

Introduction

Congratulations on your purchase of a Bushman AvonTec mechanical upender. When correctly installed, operated, and maintained, the mechanical upender is a reliable and efficient means of turning large and heavy loads. Mechanical upenders have been successfully used to turn products as diverse as large injection molds and rocket booster components, as well as their more common use as a tool for upending coils prior to mounting on a stamping line.

The Bushman AvonTec mechanical upender is designed and built to provide many years of safe and efficient service. Like any piece of industrial equipment, there are some important safety rules to follow when installing and operating this equipment. This manual provides instructions for correctly installing, using and maintaining this equipment. Due to the customized nature of the equipment some information may not apply to you upender. If you are not the first owner of this equipment, you should consult the factory before operating to ensure that its specifications are appropriate for the application.

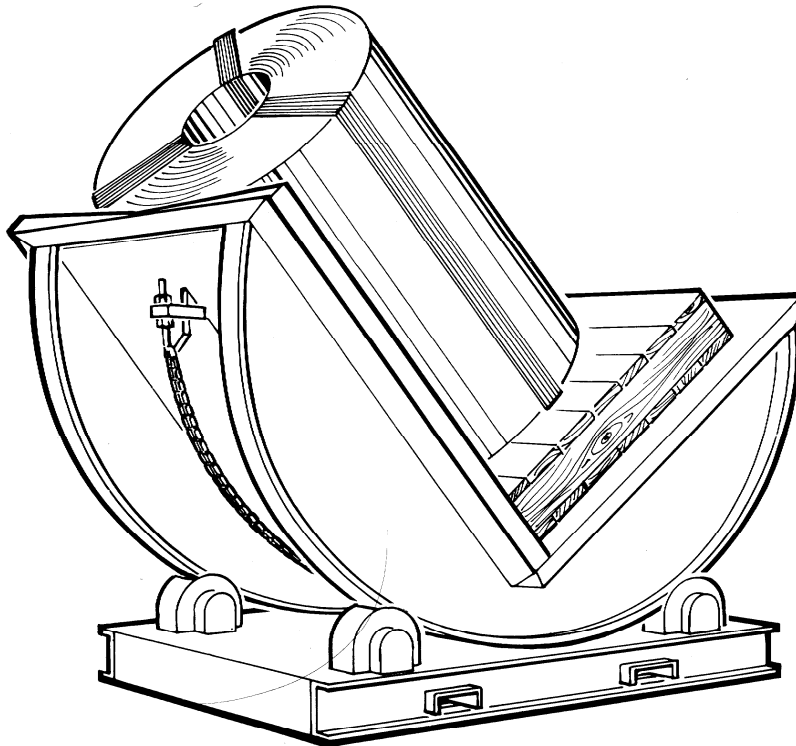

Safety Instructions

1. Do not operate this equipment unless you have been trained and authorized to do so.
2. Prior to using upender inspect it for proper operation and condition.
3. Prior to using upender, inspect all safety devices (such as upender guards) to be certain they are in place and functioning properly.
4. Do not exceed the upender's capacity as stated on the serial number plate.
5. Center loads on the upender platform.
6. If load is mobile, secure load in a fixed position before operating upender.
7. Keep the entire load within the perimeter of the platform while upender is in motion.
8. Ensure that people and objects are clear of the areas beneath the platform and immediately surrounding the perimeter of the upender while upender is in motion.
9. **DANGER!** Do not work under the upender without the maintenance device(s) in position or the upender safely blocked and secure.
10. See owner's manual for how to ensure the safe use of the maintenance device or how to block upender safely.

Responsibilities of Owners/Users

Inspection and Maintenance:

The machine shall be inspected and maintained in proper working order in accordance with the manufacturer's operating/maintenance manual and safe operating practices.

Removal from Service:

Any machine not in safe operating condition shall be removed from service until it is repaired to the original manufacturer's specifications.

Repairs:

All repairs shall be made by authorized personnel in conformance to the manufacturer's instructions.

Operators:

Only trained and authorized personnel shall be permitted to operate the machine.

Before Operation:

Before using the machine, the operator shall have:

- 1) Read and/or have explained and understood the manufacturer's operating instructions and safety rules, or be trained by a qualified person.

2) Inspected the machine for proper operation and condition. Any suspect item shall be carefully examined and a determination made by a qualified person as to whether it constitutes a safety hazard. All unsafe items shall be corrected before further use of the machine.

During Operation:

The machine shall be used only in accordance with its intended use and within the manufacturer's limitations and safety rules.

- 1) Do not overload the machine.
- 2) Ensure that all safety devices are operational and in place.

Modifications and Alteration:

Modifications or alterations of machinery shall be made with the written permission of the original manufacturer. These changes shall be in conformance with all applicable standards and shall be at least as safe as the equipment was before modification. These changes shall also satisfy all safety recommendations of the original equipment manufacturer for the particular application of the machine.

Description of Equipment

Mechanical upenders consist of two square or rectangular platform positioned at 90 degrees to each other, mounted in a cradle having the shape of a partial cylinder. The cradle rests on four bogey wheels, one at each corner of the machine. The bogey wheels are attached to a base plate that rests on the floor.

Upenders often will have a V-cradle mounted on one of the platforms. The purpose of the V-cradle is to receive coil or roll product, and to support it during the rotation process.

Operation of Equipment

Mechanical upenders are usually used to transfer coils and rolls from an "eye to the wall" position to an "eye to the sky" position, or vice versa. They may also be used to palletize or de-palletize products, or for performing maintenance on dies or other tooling.

Normal operation consists of placing a pallet against the vertical platform surface, nesting the edge of the pallet into the slot between the end of the V-cradle and the vertical platform surface. The coil or roll material is then brought to the machine and placed on the platform with the V-cradle. A variety of material handling equipment may be used to accomplish this task.

When the coil material is safely seated on the V-cradle platform, the rotation push button is activated and the machine is rotated through 90 degrees. The coil may then be removed together with the pallet on which it is resting. The equipment may also be used in the reverse mode to take material from a pallet and reorient it for further processing.

The power to rotate the cradle is provided by an electric motor that drives a sprocket through a

reduction gearbox. The sprocket engages on a chain or chains that are securely held in a circular path around the cradle of the machine. The turning of the sprocket causes the cradle to turn. Electrical limit switches positioned in the cradle limit the total rotation of the unit, usually to 90 degrees, and prevent over-rotation of the cradle.

In "dead-man" type units the push button control switch must be held down for the time necessary to rotate the load. If the push button is released before the limit switch is activated the cradle and load will stop at an intermediate position. Once the limit switch stops rotation, the machine cannot be rotated any further in that direction. Pushing the other button on the control pendant will then cause the machine to rotate in the opposite direction.

Installation

Bushman AvonTec mechanical upenders are shipped completely assembled and ready to install. If the unit is to be pit-mounted, an appropriate size pit should be prepared before moving the unit into position. (Contact factory for instructions regarding pit size, etc.)

Careful consideration should be given to placement of the upender within the plant. It should be placed on a level, dry floor, of suitable strength to bear the weight of the equipment and its load. There should be sufficient space to allow the unit to be loaded and unloaded using overhead hoists and or forklift-type material handling trucks. Consideration should also be given to the placement of the power supply cable and control box cord. Severe personal injury and or death can result if electrical cables are cut accidentally. Sufficient overhead clearance should be provided so that the largest potential load can rotate freely.

Upenders may be supplied with lag-down holes in the base plate to anchor unit to the floor. The upender must be placed on a level, flat and solid surface or damage to the rolling surfaces and drive system will occur.

The upender may be transported through the plant by one of two methods:

- 1) Lift-eyes are provided at each corner of the upender. An appropriately rated chain may be attached to each lift eye and the unit may be moved via overhead cranes or hoists. Refer to Manufacturer Plate on base of upender for weight information.
- 2) Chains attached to the lift-eyes may be lifted by a forklift-type truck.

Voltage Requirements:

The upender is designed to operate on a variety of power supply voltages. The Bushman AvonTec upender uses a multi-voltage motor; however, it is shipped with overload protection heaters appropriate to the operator requirements as specified to the factory at the time of order. If the unit is connected to a power supply with a different voltage to that originally specified to the factory, replacement overloads should be installed prior to operation. Failure to install correct overloads will result in upender failure, and can result in damage to the upender and possible serious or fatal personal injury.

Remote Motor Starter:

If the starter is mounted externally, it will be necessary to supply 3-phase power of the appropriate voltage to the starter, and then wire the starter to the motor in the base frame. In most cases, the motor leads will terminate in an outlet box in the base frame and the leads from the starter can be wired to this outlet box. A control circuit transformer is provided with the magnetic starter and additional wires will be required from the transformer to an outlet box in the base frame. These will pick up the limit switch and the push button, which can be attached to this outlet box.

Internal Motor Starter:

If the starter is mounted internally, it is necessary to knock out a hole in the enclosure box inside the base frame of the unit. If your upender was ordered with J.I.C. standard enclosures you will have to drill a hole through the enclosure and fit a gasket around the wire, a power cord should then be inserted through this hole. Attach each wire to one terminal on the motor starter, labeled L1, L2, and L3.

Operation:

After the starter and operating switches have been connected as above, and are in accordance with the attached wiring diagrams, the upender is ready to operate. The circuit breaker or disconnect switch (not supplied with the upender) is closed, and the UP-DOWN control can be operated. Unless specified otherwise, all upenders are furnished for dead man type operation where the operator keeps the UP-DOWN button depressed throughout the 90 degree travel. The Upender will stop when the button is released. Once the rotating platforms have reached the end of their cycle, they engage a limit switch, which prevents further rotation.

If the upender is furnished for maintaining operation, the operator merely depresses the UP or DOWN button and then releases it and the upender will travel 90 degrees until it reaches its limit of travel, or until the operator depresses the STOP button, at which time it will stop.

Refer to the electrical wiring diagram for connection to the power supply. Check for correct polarity. This can be done with the cradle in the "V" position. Rotate the cradle until one of the tables is near level. Jog the cradle to just past level. If the cradle stops automatically, the polarity is correct. If the table passes the limit switch and hits the manual stops, the polarity needs to be reversed. **DO NOT USE THE MANUAL STOPS AS YOUR COMMON STOPS – SEVERE DAMAGE TO THE DRIVE COMPONENTS CAN RESULT.**

DISCONNECT AND LOCK – OUT POWER SUPPLY PRIOR TO INITIAL POWER CONNECTION OR SERVICE TO ELECTRICAL COMPONENTS.

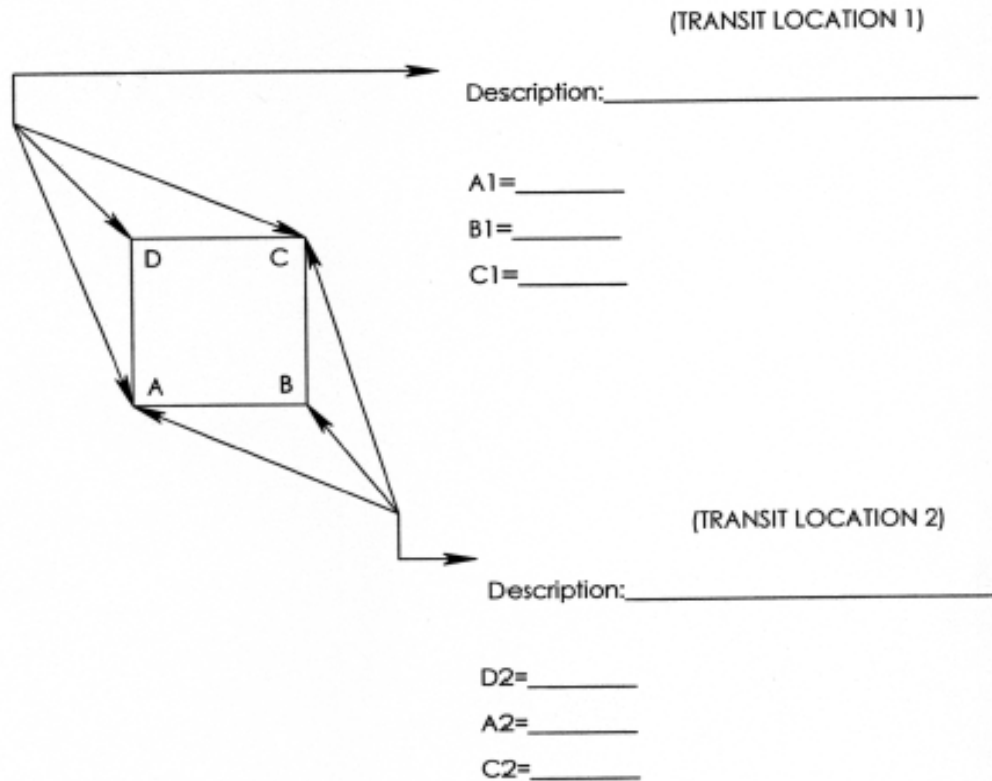

Process for leveling unit

- 1) Set up transit as illustrated for shooting the three roller shafts as shown for location 1.
- 2) Shoot each of the following pin locations and record measurements from the 3 locations.
- 3) Subtract the measurements as recorded by the locations as listed. This is to see the difference between pins.
- 4) Make pin height changes via shims at units anchoring points.
- 5) Shoot the 3 locations again to verify corrected changes.
- 6) Set up transit as illustrated for shooting the three roller shafts as shown for location 2 and follow steps 2- 5 for transit location 2.
- 7) After unit is level to requirements ensure all mounting locations are secure.

Note: Unit should be level +/- 1/32".
 The more accurate the leveling, the better the unit will operate.





Using your Upender

Upenders supplied to upend coil materials are usually supplied from the factory with a V-cradle installed on one of the platforms. The purpose of this V-cradle is to prevent sideways rolling of the circular cross-section material when it is in the core-horizontal position. If the unit is being used for down-ending, this platform will be the unload platform.

Units supplied without V-cradles can be used with either platform as the unload or load platform.

The normal downending procedure is to place the material to be downended onto the platform using either a forklift type truck or and overhead crane. On units with a v-cradle, make sure that the load is correctly nested into the v-cradle. In most cases this will ensure that the load is centered on the load platform. On units without a v-cradle, visually check that the load is centered on the platform.

WARNING!

1. Do not place loads on the upender which overhang the end of either platform or exceed the rated load capacity of the machine. Doing so places extreme stress on the motor, gearbox, and chain, and can cause breakage of these components, and severe personal injury or death.
2. Once the load to be upended is in place, you may begin rotating the platforms. The operator should ensure that the area around and underneath the machine is free of obstructions, and that persons in the area stand clear. The operator should then depress the appropriate push-button to begin rotation. Most upenders are supplied with "deadman" type operation. In these cases, it will be necessary to keep the button depressed until the platforms have reached the desired rotation angle. At the end of its cycle, the platforms engage a limit switch which halts further rotation. At this point the load may be removed from the platform.
3. In situations where the upender is being used to de-palletize loads, the operator should then remove the empty pallet from the slot between the end of the V-cradle and the vertical platform. In units fitted with a V-cradle it is also necessary to return the platform to its starting position before repeating the upending or downending cycle.

Operating Condition:

The upender should rotate smoothly, and without any scraping or banging noises. If any of these conditions are noted, the operator should immediately discontinue use of the equipment until it has been checked by qualified maintenance personnel. Jerking motion or scraping and banging noises are indications that the unit is not operating correctly, and requires maintenance. Never place any part of the body inside the upender while it is operating, or without first placing the maintenance pin in the locking position.

Chain Breakage:

Should the chain break during operation, do not attempt to service the machine until the load has been removed and the platform returned to the "balanced" 45 degree position, and the maintenance pin inserted. Chain breakage is usually an indication that the platforms are not rotating freely because of damage to the frame, or because of loading in excess of the stated capacity. Do not replace chains until the cause of the breakage has been determined and corrected. If the breakage is found to be because of overloading, contact the factory regarding possible upgrading of your existing upender. In situations where you wish to upend a load that is not unitized (e.g. a pallet load of multiple cartons, etc.) make sure that the load is secured and banded prior to upending. Do not place and straps or chains across the rolling surfaces of the upending platform.

Safe Operating Procedure

Ensure that all operators and maintenance personnel working with the equipment have read and/or had explained, and understand these safety instructions before operating or performing work on the equipment.

Failure to heed these instructions can possibly lead to severe personal injury.

1. Keep clear of the machinery at all times, and particularly when it is operating.
2. Do not climb or ride on the machine.
3. Ensure that all safety guards and limit switches are in place, and are in working order.
4. Do not enter area under the machine unless the machine has been electrically locked and tagged out, and the moving cradle has been placed and blocked in the "balanced" position.
5. The "balanced" position is when the moving cradle is halfway between its two end positions, i.e. the cradle platforms are at a 45 degree angle to both the vertical and the horizontal.
6. Never remove the chain(s) or any other component of the drive system without first ensuring that the moving cradle is in the "balanced" position and blocking it in this position. The cradle is held in the vertical and horizontal position by the chain(s) and the drive system and is unbalanced. When the chain(s) or drive system is loosened, the cradle will move rapidly to the "balanced" position, and could cause serious injury to any person close to it.
7. Should it be necessary for operational reasons to be on one of the cradle platform surfaces, always use the correct ladders, safety harnesses, and other safety equipment necessary to protect persons from falling from unprotected heights.
8. Do not bump the cradle with the product being rotated, or with cranes, crane hooks, or lift trucks. shock loads may cause failure of the chain(s) or other drive system components and could cause unexpected movement of the cradle and injury to persons.
9. Never try to lubricate moving machinery - ensure lock-out and tag-out procedures used before all lubrication and maintenance.
10. Keep rotator chain(s) correctly adjusted to prevent excess wear and stress on the drive system – see section under "chain adjustment" for instructions on adjusting chain(s).
11. Use extreme caution at all times when loading and unloading the machine to ensure that the load is always in a secure mode. Ensure that coils/rolls are correctly seated in the V-saddle before removing cranes, slings etc.
12. Do not overload the machine - see the rated capacity on the serial plate.
13. Do not rotate loads that project over front edge of the cradle platform. Ensure all loads are centrally placed and even from side to side.

Maintaining your Upender

Never perform any maintenance on your Upender without bringing the platforms to the balanced position and inserting the maintenance pin!

Daily Operator Checks:

1. Inspect the machine to ensure that all guards and limit switches are in place.
2. Check to see that the cradle is square and that one platform is square and parallel to the floor. If this is not the case, the cradle may have come off its supporting bogey wheels, or a bogey wheel bearing may have failed. If this is the case, **DO NOT** operate machine, and request maintenance assistance.
3. Before loading the machine, operate the unit unloaded through one complete cycle. Observe rotation and smoothness of operation. Report any unusual observations and/or noises, and **DO NOT** operate machine until it has been checked and repaired.
4. Check control power cord for wear.

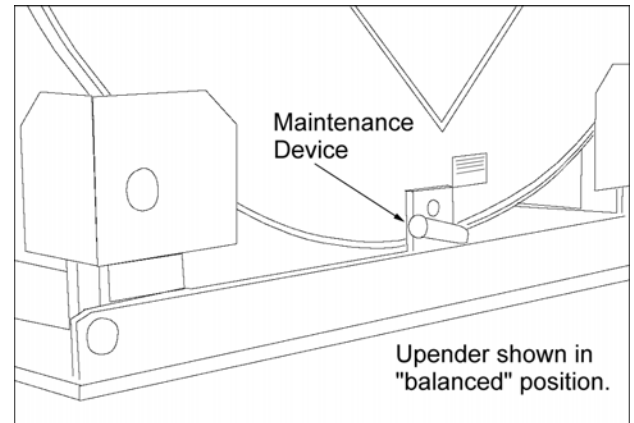

During normal operation of the machine, report any unusual observations and/or noises that may suddenly occur report these, and **DO NOT** use the machine until it has been checked by a qualified person.

Quarterly Maintenance:

The following should be performed at least quarterly by qualified maintenance personnel:

- 1) Check chains and drive components (sprockets, bushings, etc.) for wear and correct adjustment. See instructions for adjusting chains.
- 2) Check oil level in gear reducer. If necessary, bring oil to correct operating level. See section in manual covering gear box.
- 3) Flush all bearings with grease. "Zerk" type fittings are found at all bearing locations, and are fitted with a red plastic removable cap. See attached diagram for grease point locations. Use high quality 120# multi-purpose grease.
- 4) Check bogey wheels for wear.
- 5) Adjust spring-load motor brake if necessary - see details in section on brake
- 6) Check all electrical cords and components for wear.

Lubrication

Flush all bearings with grease four times a year. Bushman AvonTec recommends using a good

grade of 120# multi-purpose grease. Zerk fittings will be found at all bearing locations. Bearings are found in all members that rotate during operation around a fixed shaft or in the rollers that support the rotating cradle assembly. At the same time, the oil level in the gear box should be checked. Please consult the lubrication and maintenance information for the gearmotor that is included at the end of this manual of this manual.

Chain Tensioning & Replacement:

These upenders are driven by a powered sprocket turning a chain that is fixed to a circular plate on the back side of the upender cradle. It is necessary to maintain adequate tension in this chain and not to allow it to become slack. Slackness in the chain will result in excess wear and shock loads on the drive system.

The chain is correctly adjusted when it is held snugly against its circular backing plate. If the chain can be pulled away from the backing plate, then it is too loose and requires adjustment.

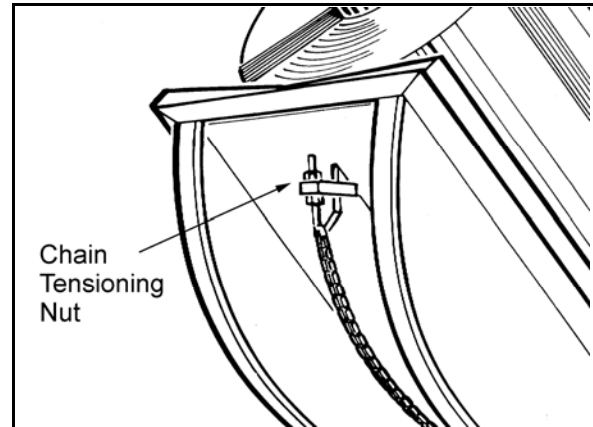

Adjustment Procedure

Remove all loads from the upender. Use the push button control to bring the upender to the "balanced" position. The "balanced" position is when the unit is rotated through 45 degrees, with both platforms pointing upward at an angle of 45 degrees. When the platforms are in this position, insert the steel maintenance pin into the hole in the side of the platform assembly and its receiving ear. This will prevent accidental movement of the platform. Disconnect power to the upender using the correct lockout procedures

Check anchor bolt adjustment range at the end of the chain. All bolts should have approximately the same amount of thread showing through the anchor nut. If this is not the case, loosen one end and tighten the other until the thread showing is approximately equal.

Tighten both anchor bolts equally until the chain is just snug against the backing plate. There should be no droop in the chain, and it should not come away from the backing plate when pulled at 90 degrees to the plate. The chain should still have some flex in it, if not it is over-tensioned.

For units with two chains, it is necessary to ensure that each chain has a similar tension. Use a torque wrench to match the tension on each chain.

Remove the maintenance-locking pin, then restore power, and observe operation of the unit. On two chain units, the cradle should rotate evenly on the bogey wheels without a tendency to move to one or the other direction. Should this happen, then one chain is tighter than the other is. If this happens, repeat until unit tracks evenly.

WARNING!

Failure to remove locking pin before restoring power can result in damage to the upender.

Chain Replacement:

Should it ever be necessary to replace chain, due to either wear or breakage, then follow the procedures above, ensuring that chain anchor bolts are correctly adjusted when the new chain is installed.

Limit Switches

Bushman AvonTec upenders are equipped with one neutral position limit switch; adjustable limit switch stops are located at each end of the 90 degree travel. The adjustable limit switch stops are set at the normal stopping position, which stops the platform in a level position. If the platform should begin to stop slightly short of 90 degrees or slightly beyond 90 degrees the limit switch stops should be re-adjusted by screwing the stop pad in or out to suit.

Contact the factory for replacement limit switch information. Do not operate the Upender until the limit switch is operating correctly.

Statement of Limited Warranty

The Bushman AvonTec will replace, F.O.B. the factory, any goods that are defective in materials and workmanship within 12 months of date of shipment, provided the buyer returns the defective materials, freight and delivery prepaid, to the manufacturer, which shall be the buyer's sole remedy for defective materials.

Manufacturer shall not be liable to purchaser or any other person or entity for consequential or incidental damages. The end user is responsible for the integrity of any structure, crane or fixture to which Bushman AvonTec products have been attached. This warranty does not apply to equipment and/or components, which have been altered in any way or subjected to abusive or abnormal use, inadequate maintenance or lubrication, or use beyond seller recommended capacities and specifications.

Manufacturer shall not be liable under any circumstances, for labor costs expended on such goods or consequential damages. Manufacturer shall not be liable to purchaser or any other person or entity for loss or damage directly or indirectly arising from the use of goods or from any other cause.

No employee, agent, officer or seller is authorized to make further oral or written representations or warranty of fitness or to waive any of the foregoing terms of sale, and none shall be binding on the manufacturer.

If there are any problems or questions regarding this equipment or its application, contact your local sales representative or Bushman AvonTec directly at 262-790-4207 or 800-338-7810.